



Rue de Lonnoux, 3  
6880 Bertrix  
+32 (0) 61 41 50 52  
www.sealuxsa.eu  
[info@sealuxsa.eu](mailto:info@sealuxsa.eu)

## Datasheet

### SEALUX-Spiral Wound Gasket



#### Generalities

The sealing element of the spiral wound gasket consists of a winding of profiled metal in a "V" shape and a more flexible filling material, usually graphite or flexible PTFE. The combination of these two elements allows for effective sealing. Indeed, the "V" construction acts as a spring, providing the gasket with excellent compression and recovery characteristics (see table below). Together, they form a robust and easy-to-install assembly. Our standard gasket thicknesses are 4.5mm, 3.2mm, and 2.5mm. Depending on the operating conditions and the type of flange, the construction of spiral wound gaskets can be customized by adding inner and/or outer rings. The purpose of the inner ring is to withstand pressure and temperature and prevent the gasket from bursting inward. The outer ring acts as a tightening limiter but also allows for proper centering of the gasket on the flanges. Depending on the application (low tightening, vacuum, etc.), the density of the spiral part can also be adjusted.

SPW Type	% Compression	% Recovery
BBBG (with inner and outer rings,SS316/graphite winding)	30	26

Variable depending on the configuration and material of the gasket.

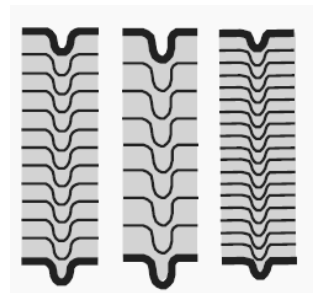



Rue de Lonnoix, 3  
 6880 Bertrix  
 +32 (0) 61 41 50 52  
 www.sealuxsa.eu  
 info@sealuxsa.eu

Sealux produces four standard types of spiral wound gaskets (C, GEGI, GI, and GE).

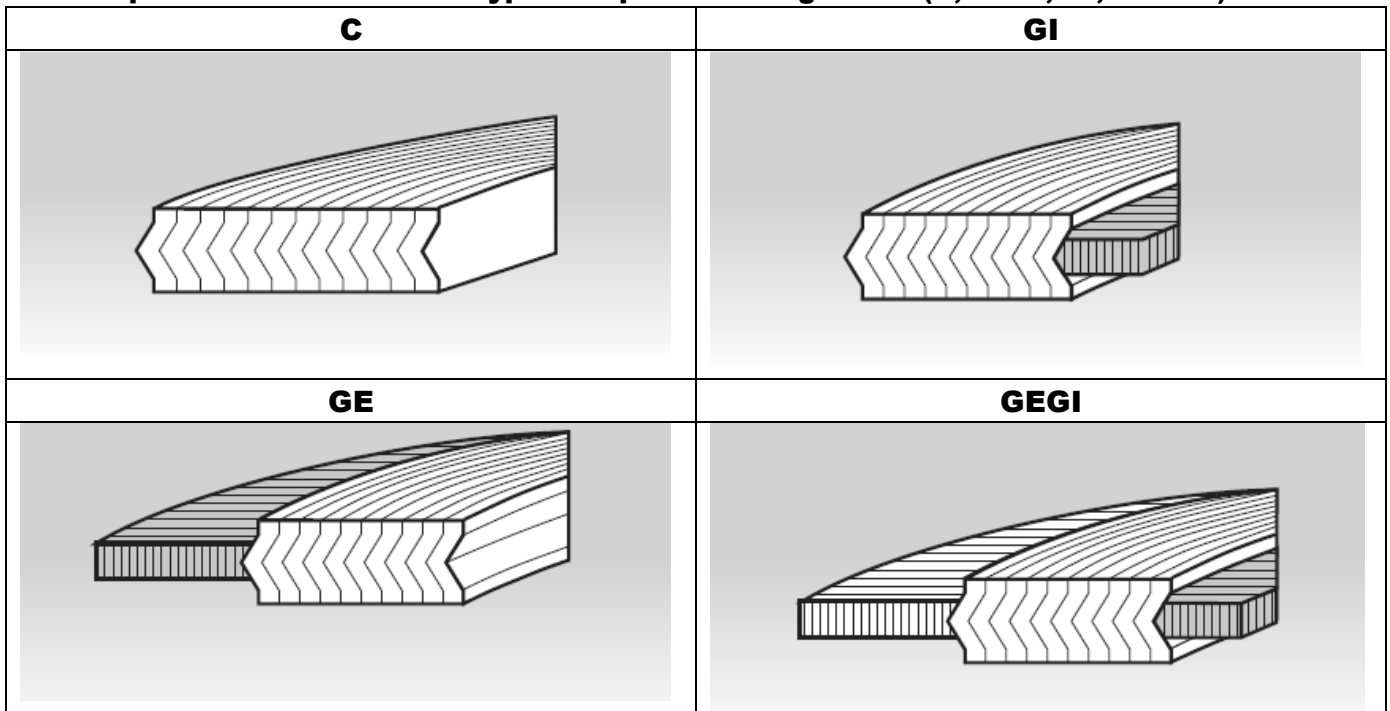

<p><b>GE type spiral wound gasket for installation on flat or RF-type flanges. It is highly recommended to maintain a distance of +/- 6.25mm between the edges of the raised surface and the inner and outer diameters of the spiral part.</b></p>	<p><b>GEGI type spiral wound gasket For installation on flat or RF-type flanges with an inner ring for high-pressure applications</b></p>	<p><b>GI type spiral wound gasket For male-female flanges. Maintain a distance of +/- 1.5mm between the outer diameter of the spiral and the outer diameter of the flange (same for the inner diameter for flanges with internal confinement).</b></p>	<p><b>C type spiral wound gasket for groove/M-F flanges (ideally used as a compression limiter). Maintain a distance of +/- 1.5mm between the inner diameter of the spiral and the inner diameter of the flange (same for the outer diameter).</b></p>

## Technical Data

### Flange: Surface Condition

The spiral wound gasket offers pipe fitters a high tolerance for the surface finish of the flanges. In general, to ensure optimal sealing, a finish (RA in  $\mu\text{m}$ ) between 3.2 and 6.3 is recommended.

The stock finish is commonly used with the spiral wound gasket. The diagrams below depict the most suitable configuration.

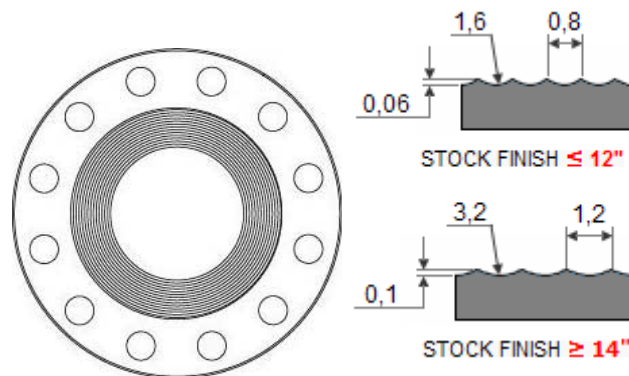

### Service conditions

Filling material		Temperature (°C)		Max Pressure(Bar)
Graphite	98%	-200	+550 (Oxygen + 450 )	350
	99.9%	-200	+550 (Oxygen + 450 )	
PTFE		-200	+250	100
Mica		-100	+1000	5 (100 with graphite zone)

Also refer to the materials section.

### Assembly/Tightening Data

The constants required for calculating the tightening torque slightly differ depending on the configuration and density of the spiral wound gasket. In general, the following values are recommended:

**ASME gasket factor**



Rue de Lonnoux, 3  
6880 Bertrix  
+32 (0) 61 41 50 52  
www.sealuxsa.eu  
info@sealuxsa.eu

Values (SS/graphite)	Low Density	Standard Density	High Density
Tightening Coefficient « m »	2	3	On request, depending on the application
Seating Stress « y »	35 MPA	70 MPA	200 MPA

#### PVRC gasket factor

GB	2300 (psi)
A	0.24
GS	13 (psi)

For optimal sealing, Sealux recommends the following compression values:

Initial Gasket Thickness	Thickness after Compression
2.5mm	1.9/2mm
3.2mm	2.3/2.5mm
4.5mm	3.2/3.4mm

These are commonly accepted general values. These values may vary depending on the gasket configuration (with or without rings), gasket density/pressure class (pressure during manufacturing), graphite strip thickness (Sealux standard: 0.5mm), and filling material (PTFE, graphite, mica, etc.). Please consult us for specific requirements.

#### Spiral Type "C": Configuration (groove/depth/width)

To design a Type "C" spiral wound gasket groove, the following criteria should be considered:

- Machine the groove height to act as a compression limiter (e.g., a depth of 2.5mm for a spiral with a height of 3.2mm).
- Maintain a distance of +/- 1.5mm between the inner diameter of the spiral and the inner diameter of the flange.
- Maintain a distance of +/- 1.5mm between the outer diameter of the spiral and the outer diameter of the flange.
- Chamfer the inner diameter of the groove at a 45° angle.

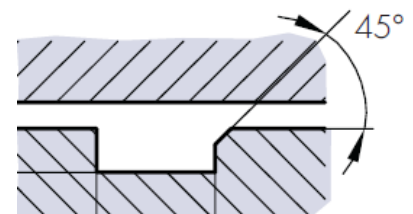

#### Selection of the Thickness for Type "C" Spiral Wound Gasket



Rue de Lonnoux, 3  
6880 Bertrix  
+32 (0) 61 41 50 52  
www.sealuxsa.eu  
[info@sealuxsa.eu](mailto:info@sealuxsa.eu)

Type	Recommended Maximum Inner Diameter			
	<250	<500	<1200	>1200
« C » (male/femelle Flange)	2.5/3.2	3.2/4.5	4.5	6.4/7.3
GE and GEGI (Raised Face Flange))	4.5	4.5	4.5	6.4/7.2
GI (Male- Female Flange))	3.2	3.2/4.5	4.5	6.4/7.2

#### Selection of the Width for Type "C" Spiral Wound Gasket

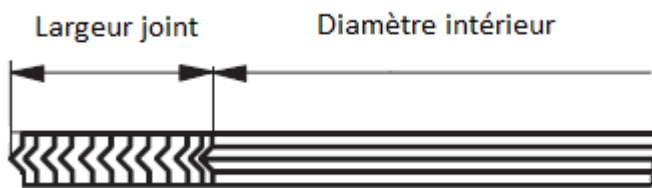

Recommended Gasket Width	Inner Diameter Range			
	->80	80 -> 800	160 -> 1000	320 ->1600
6 à 8.5mm	8.6 à 12 mm	12.1 -> 17	17.1->25	

## Materials

The combination of different materials (filling and metallic) allows for adapting the spiral wound gasket to its operating conditions, including temperature and pressure. The choice also depends on the environment in which the gasket will be installed (corrosion in oxidizing environments, compatibility with chemical substances, etc.).

#### Materials for Rings and Winding

The main concern when choosing materials is corrosion. The material used for the inner ring and winding is typically the same as that of the flanges. In cases where the outer ring is made of carbon steel, it is coated with an anticorrosion treatment (e.g., epoxy). Below is a table listing the main materials used for manufacturing spiral wound gaskets.

The main materials used by Sealux for the metallic winding and rings are:



Rue de Lonnoux, 3  
 6880 Bertrix  
 +32 (0) 61 41 50 52  
[www.sealuxsa.eu](http://www.sealuxsa.eu)  
[info@sealuxsa.eu](mailto:info@sealuxsa.eu)

Trade Name	DIN Material N°	T°C Minimum	T°C Maximum	Comment
Carbon Steel	1.0038	-40	500	For standard applications
SS304L	1.4306	-250	540	Corrosion resistance
SS316L	1.4404	-196	815	
SS321	1.4541	-250	870	Temperature resistance
SS347	1.4550	-250	870	
Titanium	3.7025		1095	Specific applications (strong acids, strong bases, high temperature, etc.)
Inconel 600	2.4816		1095	
Inconel 825	2.4858		1095	
Monel 400	2.4360		820	
Hastelloy B2	2.4617		1095	

#### Filling Materials

Sealux is capable of producing spiral wound gaskets with the following filling materials:

Filling Materials		Temperature (°C)		Max Pressure (Bar)
Graphite	98%	-200	+550 (Oxygen + 450 )	350
	99.9%	-200	+550 (Oxygen + 450 )	
PTFE		-200	+250	100
Mica		-100	+1000	5 (100 with graphite zone)

In most cases, graphite filling is recommended. Other sealing fillings are available and used when graphite poses risks of media contamination. It is also possible that graphite is not chemically compatible or that the temperature exceeds the graphite's operating limit. See the table above.

For hydrogen applications, we recommend using an SS316L stainless steel spiral wound gasket with PTFE filling. Both materials are compatible for use in contact with hydrogen.

Please feel free to contact us with your service conditions to determine the best manufacturing parameters.

Oxidation is an important factor to consider when choosing the filler material. At high temperatures, graphite is highly sensitive to the presence of oxygen. The rate at which



Rue de Lonnoux, 3  
6880 Bertrix  
+32 (0) 61 41 50 52  
www.sealuxsa.eu  
[info@sealuxsa.eu](mailto:info@sealuxsa.eu)

graphite transforms into carbon oxide depends on factors such as temperature, oxygen concentration, and carbon purity level (positive correlation). The table below (TTRL report) illustrates this phenomenon.

Required Service Life Years	Maximum Service Temperature	
	°C	°F
1	370	691
3	330	630
5	320	610
10	305	580



Oxidized spiral wound gasket

To counteract this phenomenon, it is highly recommended to:

- 1) Use an inner ring (first barrier against corrosion).
- 2) Apply proper tightening (expose only the inner edge of the gasket).
- 3) If necessary, consider using alternative filler materials (mica, vermiculite, etc.).

## Manufacturing

In addition to standard products, Sealux has the capability, thanks to its machines, to produce custom spiral wound gaskets, as well as oval-shaped and barretted spiral wound gaskets (for heat exchangers), and more.

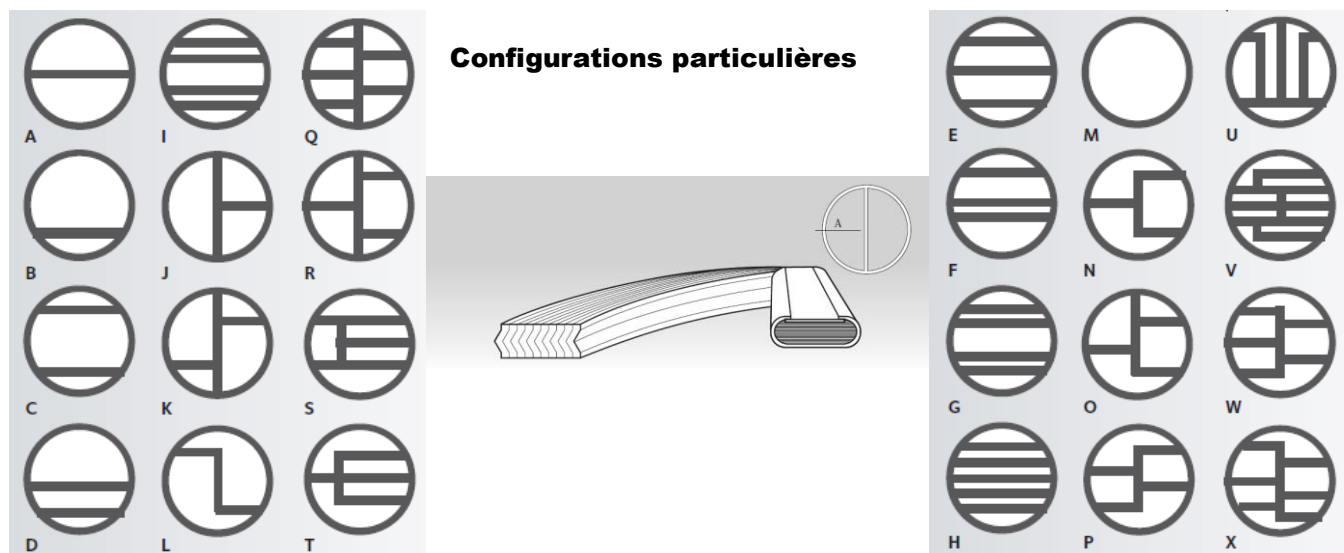

Sealux has a stock of the majority of the materials mentioned above, allowing them to respond promptly to your specific requests. Our flexible machinery enables efficient and cost-effective production of small, medium, and large batches.



Rue de Lonnoux, 3  
6880 Bertrix  
+32 (0) 61 41 50 52  
www.sealuxsa.eu  
info@sealuxsa.eu

**Tolerances**

Sealux adheres to the tolerance standards recommended by ASME 16.20 and EN 1514-2.

**Type GEGI/GE**

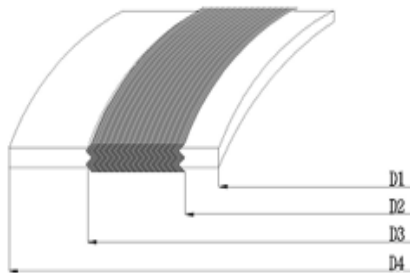

Gasket/Winding			Inner and outer ring
Thickness	Tolerances	Compressed Thickness	Thickness
3.2	± 0.13	2.3 ~ 2.5	2.0
4.5	± 0.13	3.2 ~ 3.4	3.0
6.4	± 0.13	4.6 ~ 5.1	4.0
7.2	± 0.13	5.1 ~ 5.6	5.0

ASME B16.20				Tolerance (mm)
	ANSI B16.5	ANSI B16.47-A	ANSI B16.47-B	
D1	1/2" ~ 3"	-	-	± 0.8
	4" ~ 24"	-	-	± 1.5
	-	26" ~ 60"	26" ~ 60"	± 3.0
D2	1/2" ~ 8"	-	-	± 0.4
	10" ~ 24"	-	-	± 0.8
	-	26" ~ 34"	26" ~ 34"	± 0.8
	-	36" ~ 60"	36" ~ 60"	± 1.3
D3	1/2" ~ 8"	-	-	± 0.8
	10" ~ 24"	-	-	+ 1.5 / - 0.8
	-	26" ~ 60"	26" ~ 60"	± 1.5
D4	1/2" ~ 24"	-	-	± 0.8
	-	26" ~ 60"	26" ~ 60"	± 0.8

**Type C et GI**

<b>Dia Int (D1/D2)</b>	<b>-0</b>	<b>+0.6</b>	<b>D3 (dia ext)</b>	<b>-0.6</b>	<b>+0</b>
------------------------	-----------	-------------	---------------------	-------------	-----------



Rue de Lonnoux, 3  
6880 Bertrix  
+32 (0) 61 41 50 52  
[www.sealuxsa.eu](http://www.sealuxsa.eu)  
[info@sealuxsa.eu](mailto:info@sealuxsa.eu)

## ASSEMBLY ADVICE

### ASSEMBLY

Ensure that the flange faces are parallel, aligned, clean, and meet all the conditions listed above.

Ensure that there are no signs of leakage, such as dents, scratches, or deformations.

Ensure that the fasteners are in good condition.

Lubricate the bolts, nuts, and washer contact surfaces (the friction coefficient of the lubricant significantly affects the tightening calculation).

### STORAGE

Store the gaskets flat and protected from moisture. Also, avoid placing heavy loads on the gasket.

### HANDLING

Handle the gaskets with care to avoid any risk of damaging the spiral part. Blows, deep scratches, and deformations can compromise the sealing.

### TIGHTENING PROCEDURE

Place the gasket and ensure proper centering.

Tighten the fasteners according to the attached diagram, at 30% of the previously calculated load.

Continue tightening by alternating the flange faces until reaching the recommended stress (in 3 or 4 stages) and no longer observe nut rotation.

As a general rule, do not loosen and re-tighten fasteners to a lower or even identical torque. This operation can result in unpredictable joint performance.

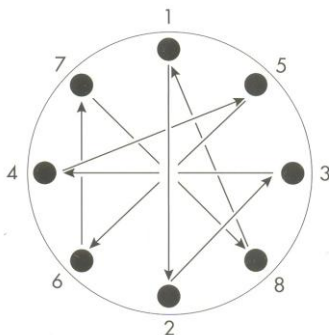



Rue de Lonnoix, 3  
 6880 Bertrix  
 +32 (0) 61 41 50 52  
[www.sealuxsa.eu](http://www.sealuxsa.eu)  
[info@sealuxsa.eu](mailto:info@sealuxsa.eu)

**Tightening Torque:**

**Ideally, it is recommended to calculate the tightening torque based on the constants mentioned above and taking into account factors such as internal system pressure and the type of lubrication used in the tightening system. However, the table below provides indicative tightening torque values (N/m) for GEGI gaskets according to ASME B16.20 standard. These tightening torques are established based on a specific tightening system: bolt (ASTM A193 B7), nut (ASTM A194 2H), and lubrication (oil/graphite).**

Size of pipe	Bolts number	Bolt Size (inches)	Class 150		Class 300		Class 400		Class 600		Class 900		Class 1500		Class 2500	
			Couple Min	Couple Max	Couple Min	Couple Max	Couple Min	Couple Max	Couple Min	Couple Max	Couple Min	Couple Max	Couple Min	Couple Max	Couple Min	Couple Max
0.5	4	0.5	41	68	41	54	41	54	41	54	95	163	95	136	68	136
0.75	4	0.5	41	68	81	108	81	108	81	108	95	163	95	136	85	136
1	4	0.5	41	81	81	108	81	108	81	108	149	258	149	217	149	217
1.25	4	0.5	41	81	81	108	81	108	81	108	149	258	190	222	285	339
1.5	4	0.5	41	81	136	190	136	190	136	190	230	393	271	339	420	488
2	4	0.63	81	163	81	108	81	108	81	108	149	258	176	230	298	339
2.5	4	0.63	81	163	136	190	136	190	136	190	230	393	258	339	407	488
3	4	0.63	122	163	136	203	136	203	136	203	190	312	366	488	624	678
4	8	0.63	95	163	136	271	217	434	258	434	353	569	569	705	963	1085
5	8	0.75	136	271	149	271	285	434	380	664	488	813	800	1085	1735	2034
6	8	0.75	176	271	149	271	258	434	353	624	407	678	719	922	2535	2983
8	8	0.75	244	271	244	434	420	664	542	949	658	1085	1152	1491	2413	2983
10	12	0.88	230	434	339	624	488	963	678	1085	685	1085	2129	2712	4122	5966
12	12	0.88	325	434	488	949	691	1356	678	1152	759	1152	2034	2983	6250	8026
14	12	1	407	664	488	827	678	1180	922	1288	854	1274	2874	4312		
16	16	1	420	664	678	1247	922	1695	1085	1641	1234	1749	3986	5966		
18	16	1.13	664	963	678	1356	922	1817	1491	2427	2129	3173	5355	8026		
20	20	1.13	583	963	678	1356	1085	1939	1491	2224	2366	3484	6982	10467		
24	20	1.25	841	1356	1085	2169	2034	3078	2712	3620	3993	6969	11308	16948		



Rue de Lonnoux, 3  
 6880 Bertrix  
 +32 (0) 61 41 50 52  
[www.sealuxsa.eu](http://www.sealuxsa.eu)  
[info@sealuxsa.eu](mailto:info@sealuxsa.eu)

Dimensional Table:

Norme DIN pour joints spiralés GEGI

DN en mm	D1	D2	D3		D4								
	PN10 à PN320	PN10-40	PN64-320	PN10	PN16	PN25	PN40	PN64	PN100	PN160	PN250	PN320	
10	18	24	36	36	46	46	46	46	56	56	56	67	67
15	22	28	40	40	51	51	51	51	61	61	61	72	72
20	27	33	47	47	61	61	61	61	74	74	74	79	
25	34	40	54	54	71	71	71	71	82	82	82	82	92
32	43	49	65	65	82	82	82	82	90	90	90	100	
40	48	54	70	70	92	92	92	92	102	102	102	108	118
50	57	66	84	84	107	107	107	107	112	118	118	123	133
65	73	82	102	104	127	127	127	127	137	143	143	153	170
80	86	95	115	119	142	142	142	142	147	153	153	170	190
100	108	120	140	144	162	162	167	167	173	180	180	202	229
125	134	146	168	172	192	192	193	193	210	217	217	242	274
150	162	174	196	200	217	217	223	223	247	257	257	284	311
175	183	195	221	227	247	247	253	265	277	287	284	316	358
200	213	225	251	257	272	272	283	290	309	324	324	358	398
250	267	279	307	315	327	328	340	352	364	391	388	442	488
300	318	330	358	366	377	383	400	417	424	458	458	538	
350	363	375	405	413	437	443	457	474	485	512			
400	414	426	458	466	488	495	514	546	543	572			
500	518	530	566	574	593	617	624	628	657	704			
600	618	630	666	674	695	734	731	747	764	813			
700	718	730	770	778	810	804	833	852	879				
800	818	830	874	882	917	911	942	974	988				
900	910	930	974	982	1017	1011	1042	1084	1108				
1000	1010	1030	1078	1086	1124	1128	1154	1194	1220				



Rue de Lonnoix, 3  
 6880 Bertrix  
 +32 (0) 61 41 50 52  
[www.sealuxsa.eu](http://www.sealuxsa.eu)  
[info@sealuxsa.eu](mailto:info@sealuxsa.eu)

Norme ASME B16.20 pour joints spiralés GEGI																			
Inch/Lbs	D1					D2					D3		D4						
	150/300	400/600	900	1500	2500	150/300	400/600	900	1500	2500	150->600	900->2500	150	300	400	600	900	1500	2500
0,5	14,2	14,2	14,2	14,2	14,2	19,1	19,1	19,1	19,1	19,1	31,8	31,8	47,8	54,1	54,1	54,1	63,5	63,5	69,9
0,75	20,6	20,6	20,6	20,6	20,6	25,4	25,4	25,4	25,4	25,4	39,6	39,6	57,2	66,8	66,8	92,2	69,9	69,9	76,2
1	26,9	26,9	26,9	26,9	26,9	31,8	31,8	31,8	31,8	31,8	47,8	47,8	66,8	73,2	73,2	73,2	79,5	79,5	85,9
1,25	38,1	38,1	33,3	33,3	33,3	47,8	47,8	39,6	39,6	39,6	60,5	60,5	76,2	82,6	82,6	82,6	88,9	88,9	104,9
1,5	44,5	44,5	41,4	41,4	41,4	54,1	54,1	47,8	47,8	47,8	69,9	69,9	85,9	95,3	95,3	95,3	98,6	98,6	117,6
2	55,6	55,6	52,3	52,3	52,3	69,9	69,9	58,7	58,7	58,7	85,9	85,9	104,9	111,3	111,3	111,3	143	143	146,1
2,5	66,5	66,5	63,5	63,5	63,5	82,6	82,6	69,9	69,9	69,9	98,6	98,6	124	130,3	130,3	130,3	165,1	165,1	168,4
3	81	81	81	81	81	101,6	101,6	95,3	92,2	92,2	120,7	120,7	136,7	149,4	149,4	149,4	168,4	174,8	196,9
4	106,4	106,4	106,4	106,4	106,4	127	120,7	120,7	117,6	117,6	149,4	149,4	174,8	181,1	177,8	193,8	206,5	209,6	235
5	131,8	131,8	131,8	131,8	131,8	155,7	147,6	147,6	143	143	177,8	177,8	196,9	215,9	212,9	241,3	247,7	254	279,4
6	157,2	157,2	157,2	157,2	157,2	182,6	174,8	174,8	171,5	171,5	209,6	209,6	222,3	251	247,7	266,7	289,1	282,7	317,5
8	215,9	209,6	209,6	206,2	200,2	233,4	225,6	222,3	215,9	215,9	263,7	257,3	279,4	308,1	304,8	320,8	358,9	352,6	387,4
10	268,2	260,4	260,4	257,8	247,7	287,3	274,6	276,4	266,7	270	317,5	311,2	339,9	362	358,9	400,1	435,1	435,1	476,3
12	317,5	317,5	314,5	314,5	292,1	339,9	327,2	323,9	323,9	317,5	374,7	368,3	409,7	422,4	419,1	457,2	498,6	520,7	549,4
14	349,3	349,3	342,9	339,9	371,6	362	355,6	362	406,4	400,1	450,9	485,9	482,6	492,3	520,7	577,9			
16	400,1	400,1	393,7	387,4	422,4	412,8	412,8	406,4	463,6	457,2	514,4	539,8	536,7	565,2	574,8	641,4			
18	449,3	449,3	444,5	438,2	474,7	469,9	463,6	463,6	527,1	520,7	549,4	596,9	593,9	612,9	638,3	704,9			
20	500,1	500,1	495,3	489	525,5	520,7	520,7	514,4	577,9	571,5	606,6	654,1	647,7	682,8	698,5	755,7			
24	603,3	603,3	603,3	577,9	628,7	628,7	628,7	616	685,8	679,5	717,6	774,7	768,4	790,7	838,2	901,7			